

KP100 King Pin Lock Data Sheet



Fig 1.



Fig 2.

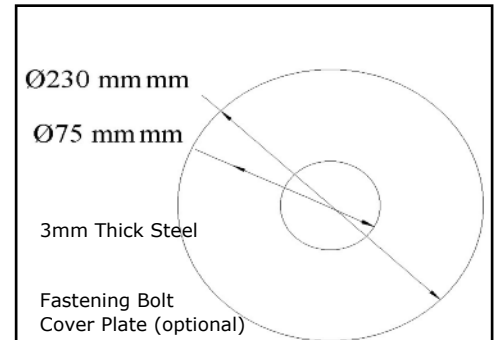

Fig 3.

Features:

- Main body manufactured from impact resistant, SG iron.
- Uses Bulldog Super Lock Bolt. Case hardened 1" (25.4mm) diameter body. Drill and pick resistant lock with over one million possible key combinations. (See separate sheet).
- 2 keys supplied with lock as standard. Multiple locks can be supplied with same key for fleet or multi user applications.
- Lock bolt can only be locked using key, no accidental locking possible.
- King Pin Lock comes with a PVC carrier for clean, grease free handling and storage.
- Finished in a highly visible, yellow powder coating.
- Warning label included in kit to remind driver to check for Bulldog King Pin Lock before attempting to hitch up to trailer.
- Also available, optional fastening bolt cover plate. (See Fig 3).
- Independantly tested and approved by SCM. Approval No. MP030416.
- Weight = 5.5kg

Fits standard 2" (51mm) King Pins

Bulldog Security Products Ltd
Units 1 - 4 Stretton Road, Much Wenlock, Shropshire, TF13 6DH.
Tel: 01952 728171 Fax: 01952 728117
Email: sales@bulldogsecure.com www.bulldogsecure.com