

VA101 Van Door Lock (Rear Door) Fitting Instruction

1. Position the door lock assembly as shown.

Parts List.

- 1 off Lock Tube c/w Lock
- 1 off Guide Tube
- 1 off Slider
- 2 off Packer Plates 60 x 32 x 3 thick
- 2 off Back Plates 60 x 20 x 6 thick
- 4 off M8 x 35 CSK Head Fasteners
- 4 off M8 Nyloc Nuts
- 1 off 5mm Allen Key
- 1 off M10 x 50 Grub Screw

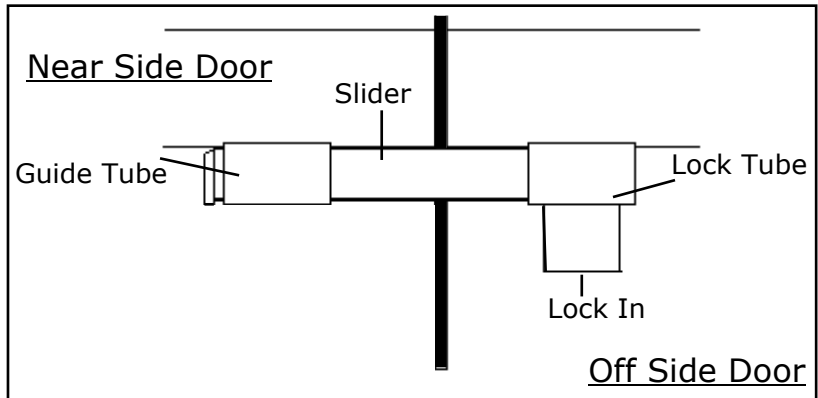

2. With the lock engaged in the slider, mark out position of lock tube and guide tube onto rear door with a pencil, unlock slider, then mark out each hole position. (Use a packer plate as a template to mark hole centres).

Important. Before drilling the fixing holes re-check suitability of the fixing position ensuring hole positions are away from door linkages, wiring etc. Then carefully drill through panels with 9mm dia drill bit.

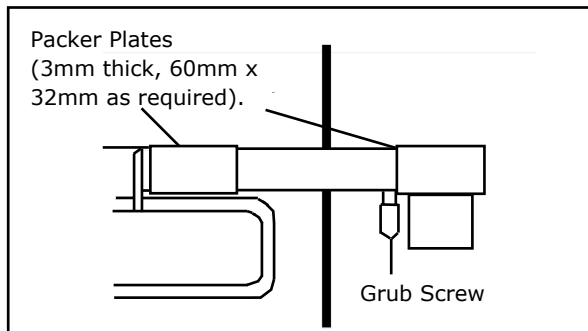

3. Fit the lock and guide tubes to the rear doors using the countersunk fasteners provided using packer plates between the doors and the tubes as required to gain best alignment. Use 5mm hexagon key to hold fasteners when tightening.

4. Fit two re-inforcing plates (20mm wide) inside the van and tighten the locking nuts.

5. The 10mm grub screw handle can now be fitted as shown.

Note:- The top hole is not threaded, it is a seating for the grub screw, do not over tighten.

6. Fit cover cap to the grub screw handle.

To Lock. Remove key, push slider fully across and press lock into hole in slider until lock clicks.

To Unlock. Insert key, rotate half turn and pull on key until lock pops out.

We have taken every care in the design and manufacture of this security device and we believe that it is an effective deterrent. However we cannot guarantee that it will resist the efforts of the most determined thief, and as such we do not accept any liability for loss or damage caused by theft, vandalism or other illegal activity against property to which this device is fitted.

Bulldog Security Products

Units 1 - 4 Stretton Road, Much Wenlock, Shropshire, TF13 6DH.
Tel: 01952 728171
Email sales@bulldogsecure.com www.bulldogsecure.com

Lock Lubrication.

IMPORTANT - To ensure free movement of the lock, spray lock mechanism with WD40 (or equivalent) minimum every four months.