

# 'QS' Bulldog Quick Release Kit Fitting Instructions

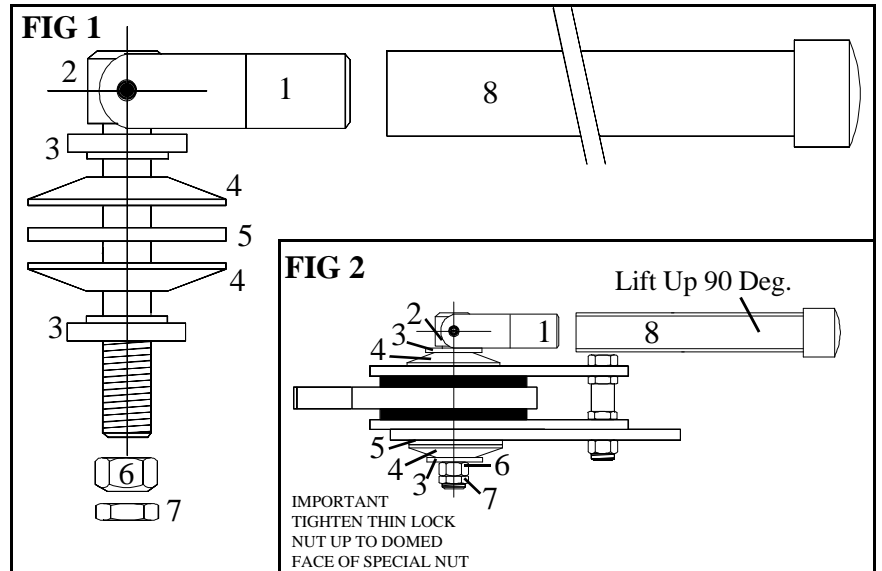

## The Kit Includes:

- Item 1 - Cam Release
- Item 2 - Retaining Bolt with 'Safety Head'
- Item 3 - Retaining Washers - 2 Off
- Item 4 - Disc Springs - 2 Off
- Item 5 - Large Flat Washer
- Item 6 - Special Locking Nut
- Item 7 - Thin 12mm Lock Nut
- Item 8 - Tubular Detachable Handle



## Step No 1.

Remove and discard the existing 12mm centre nut and bolt and the depressed washer or disc spring.

## Step No 2.

From the kit assemble items 1 to 4 as Fig 1 shows.

## Step No 3.

Slide the retaining bolt (item 2) through the stabiliser and fit the large flat washer (item 5) up to the leaf spring. Fit the second disc spring (item 4) and retaining washer (item 3) up to the bottom of the stabiliser as Fig 2 shows.

## Step No 4.

Fit the handle (item 8) onto the cam release spigot to act as a lever and hold horizontal. Fit the special locking nut (item 6) - (take care that the dome is at the bottom), and run it up the thread until the two disc springs bite into the stabiliser.

## Step No 5.

Try the push/pull force at the end of the spring arm (as per manufacturer's standard fitting instructions). The force can be measured with a set of bathroom scales and should be approx 60 lbs - this is not a torque figure. Please do not use a torque wrench. Tighten or loosen the special locking nut (item 6) until the correct setting is obtained. Use the handle on the spigot to prevent movement of retaining bolt.

## Step No 6.

Fit the thin 12mm lock nut (item 7) and tighten up to the domed face of the special locking nut (item 6). Use two spanners and take care not to move the special locking nut (item 6).

## Step No 7.

Using the handle supplied lift up the cam to release the pressure off the friction discs. It should be now relatively easy to move the spring arm from side to side. If you consider it not easy enough, check the force at the end of the spring arm and re-adjust the lock nuts as necessary.

## Step No 8.

It is advised that a light smear of grease at the end of the thread will help prevent weathering. After the initial 50 miles, check the tightness of the thin lock nut to the special locking nut (items 7 and 6).

## **BULLDOG SECURITY PRODUCTS LIMITED**

Units 2,3,4 Stretton Road , Much Wenlock, Shropshire, TF13 6DH. Tel: 01952 728171 Fax: 01952 728117

email: [sales@bulldog-security-products.co.uk](mailto:sales@bulldog-security-products.co.uk) web site: <http://www.bulldog-security-products.co.uk>