

AW Mini Lock Fitting Instructions

WARNING: Before unlocking Mini Lock with keys provided, please remember to support base with hand **i.e. Mind your feet**

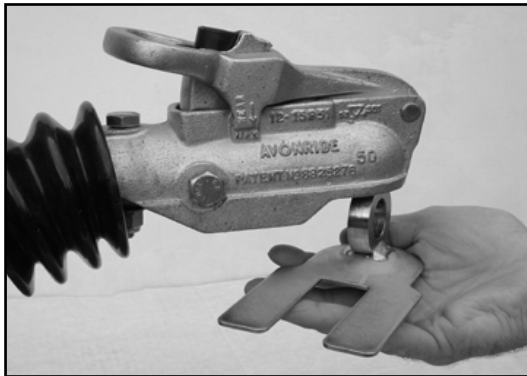

1. Insert dummy ring plate when trailer is unhitched by offering up at an angle and twisting into place.

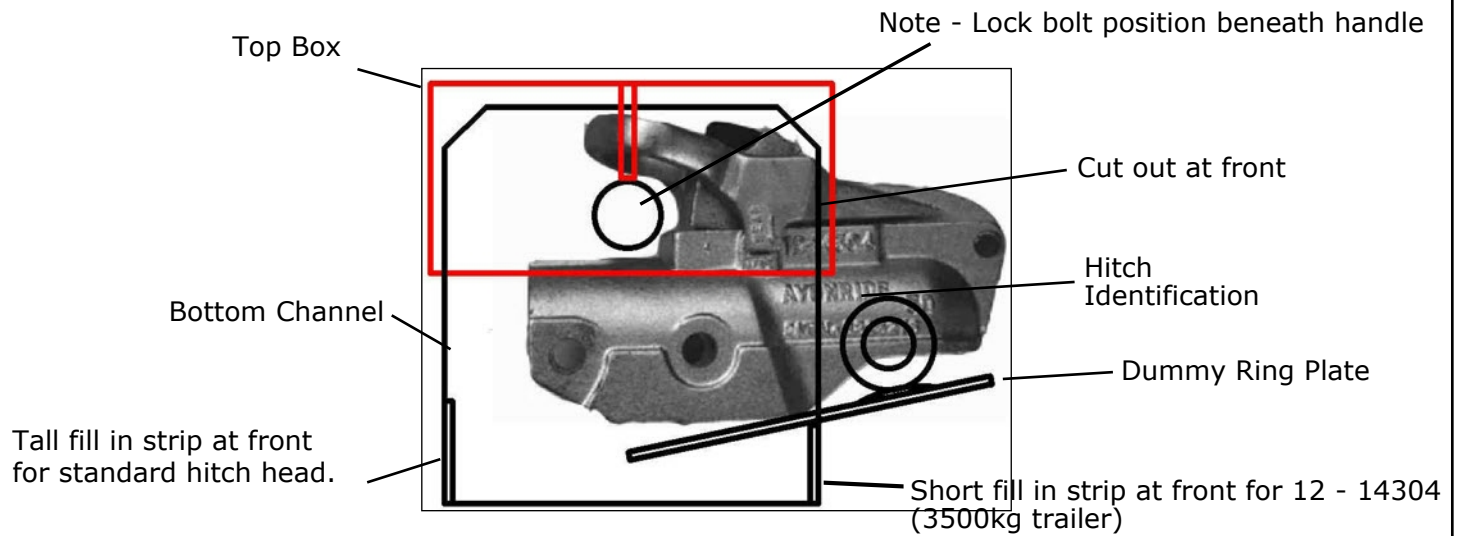
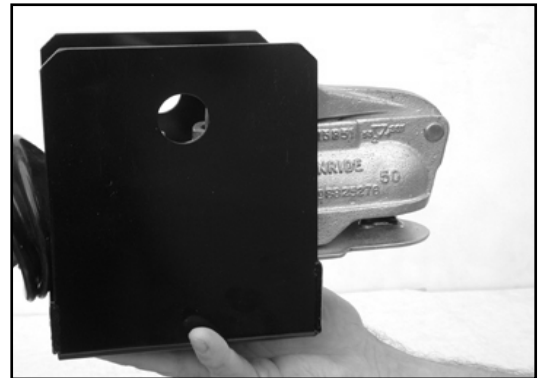

2. Offer up bottom channel according to your hitch type. Short fill strip at front for 12 - 14304 or tall fill in strip at front for standard hitch head.

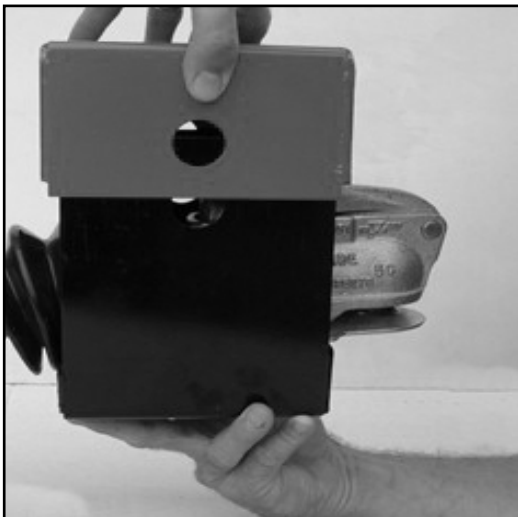

3. Place the red top box (with cut out facing front) over the bottom channel and lower until holes line up in both.

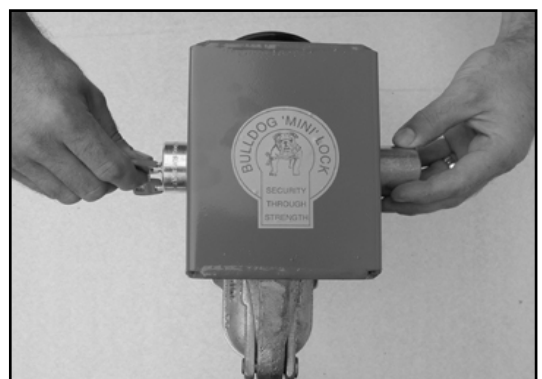

4. Insert Bulldog Super Lock Bolt through holes and put cup over the end. Turn key quarter turn clockwise to lock and remove key.

Note:

When using this minilock with the 12-14304 (3.5 tonne trailers) hitch ensure the nut that secures the horizontal bolt is located on the offside. Failure to do so may result in difficulty fitting this product. Should the bolt need to be changed around, ensure it is done so by a competent person and correctly tightened.

Bulldog Security Products

Units 1 - 4 Stretton Road, Much Wenlock, Shropshire, TF13 6DH.
Tel: 01952 728171
Email sales@bulldogsecure.com www.bulldogsecure.com

Lock Lubrication.

IMPORTANT - To ensure free movement of the lock, spray lock mechanism & ball bearings with WD40 (or equivalent) minimum every four months.